



OVERVIEW

The Axxess Load Control Module (“LCM”) is designed to control a line voltage dimmable lighting load using phase-cut dimming (leading-edge or trailing-edge) to set the desired light level.

The LCM is controlled by an Axxess Touch Keypad or via automation system (via ZigBee wireless or RS485), or via 0-10V wired dimming control.

* Note: The maximum and minimum load limits for LED fixtures and fluorescent/compact fluorescent can vary depending on the the specific fixture and/or bulb being used. At higher wattages, these load types may have significant in-rush current which can trip the protection circuitry on the control. Conversely, At low wattages, some CFL and LED loads will not be able to completely shut off. When using these load types, it is recommended to test in advance as the load range and dimming performance varies for different bulb manufacturers and bulbs. This device IS NOT DESIGNED for magnetic low voltage loads.

SPECIFICATIONS

POWER INPUT:	NORTH AMERICA: 100-277V~ 60/50 Hz WORLD: 100-260V~ 50/60Hz
SUPPORTED LOAD TYPES:	INCANDESCENT; HALOGEN; DIMMABLE LED BULBS AND DIMMABLE FLUORESCENT, COMPACT FLUORESCENT BULBS NOTE: DO NOT CONNECT MAGNETIC LOW VOLTAGE LOADS
MAXIMUM LOAD	NORTH AMERICA: 2.0A, I.E. 240W @120V, 554W @277V WORLD: 1.8A, I.E. 432W @240V
MINIMUM LOAD	0.05A, I.E. 6W @120V, 12W @240V
SELV CIRCUITS (COMBINED)	9.5VDC, 2.4W
OPERATING TEMPERATURE:	ALL LOAD RATINGS ARE BASED ON AN AMBIENT TEMPERATURE OF 25 DEGREES CELSIUS.
CONTROL COMMUNICATIONS:	ZIGBEE WIRELESS, RS485, 0-10V
DIMENSIONS	45mm x L 51mm x H 27mm
RADIO COMPLIANCE	FCC PART 15 IC CE C-TICK
APPROVALS	CB, cTUVus

Load Control Module

IMPORTANT: WARNINGS AND CONSIDERATIONS

⚠ Warning! Install in accordance with all applicable national and local electrical codes.

⚠ Warning! To be installed by a qualified electrician/technician who is licensed under applicable laws and regulations.

⚠ Warning! Improper installation or use can cause **SERIOUS INJURY, DEATH or LOSS/DAMAGE OF PROPERTY.**

⚠ Warning! If you are unsure about any of these instructions, consult the manufacturer or its dealer.

CAUTION! Do not install to control a plug receptacle.

IMPORTANT! Using this product in a manner other than outlined in this document, or installation by a person not licensed to do so, voids product warranty.

IMPORTANT! Opening the product case or making changes or modifications to the LCM voids product warranty.

IMPORTANT: AVERTISSEMENTS ET CONSIDÉRATIONS

⚠ Avertissement! Installez ce produit selon tous les codes électriques nationaux et locaux applicables.

⚠ Avertissement! Ce produit doit être installé par un électricien/technicien qualifié et autorisé par les lois et règlements applicables.

⚠ Avertissement! L'installation ou l'utilisation non conforme de ce produit peut causer de **BLESSURES GRAVES, LA MORT, DES PERTES OU DES DOMMAGES MATÉRIELS.**

⚠ Avertissement! Veuillez consulter le fabricant ou le vendeur si vous avez des questions à propos de ces instructions.

ATTENTION! Ne pas installer pour contrôler une prise de courant.

IMPORTANT! L'utilisation de ce produit dans une autre façon que celles décrites dans ce document ou une installation faite par une personne non autorisée annule la garantie du produit.

IMPORTANT! L'ouverture du boîtier du produit ou sa modification annule la garantie du produit.

Load Control Module

INSTALLATION INSTRUCTIONS

NOTE: The Axxess LCM can be wired and installed several different ways. Please follow the instructions below that are appropriate for your installation.

The range and performance of the ZigBee wireless control system is dependent on various factors, including distance, attenuating materials such as walls, interference, etc. Keep this in mind when selecting the installation location.

DO NOT exceed the maximum load rating of the device (see the previous section, "Specifications and Supported Fixtures").

Switch off and isolate the mains power at the branch circuit breaker panel or fusebox before starting any installation or maintenance.

Typically the LCM will be installed in an electrical box with the help of a mounting bracket. Axxess has several mounting bracket options which are appropriate for different electrical boxes. (see Figure 1) All mounting brackets have the same diagonal holes for mounting the bracket to the LCM. (see Figure 2) The differences lie in the mounting hole position for the different styles of electrical boxes. Select the bracket that is suitable for the electrical box mounting holes. (see

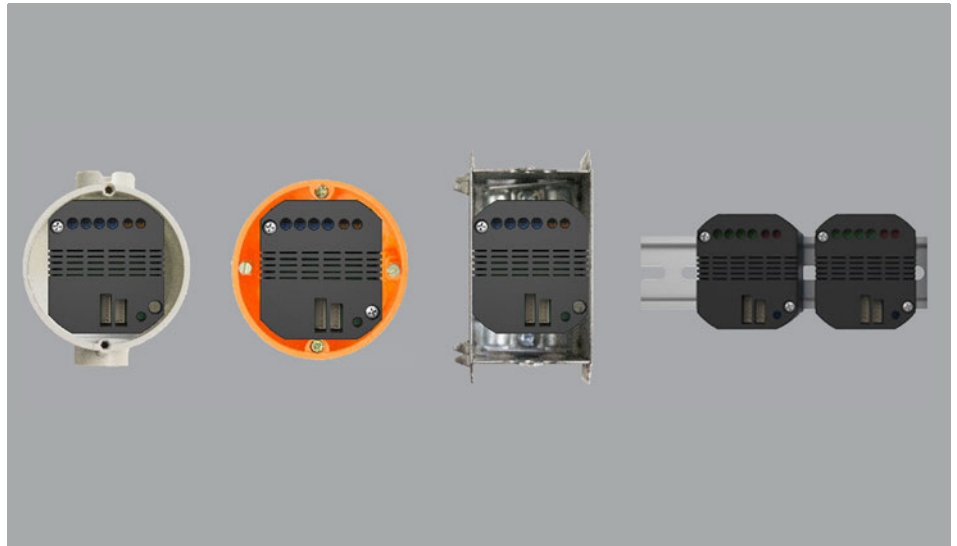

Figure 1: LCM shown in single gang Euro and US wallboxes (bracket not shown)

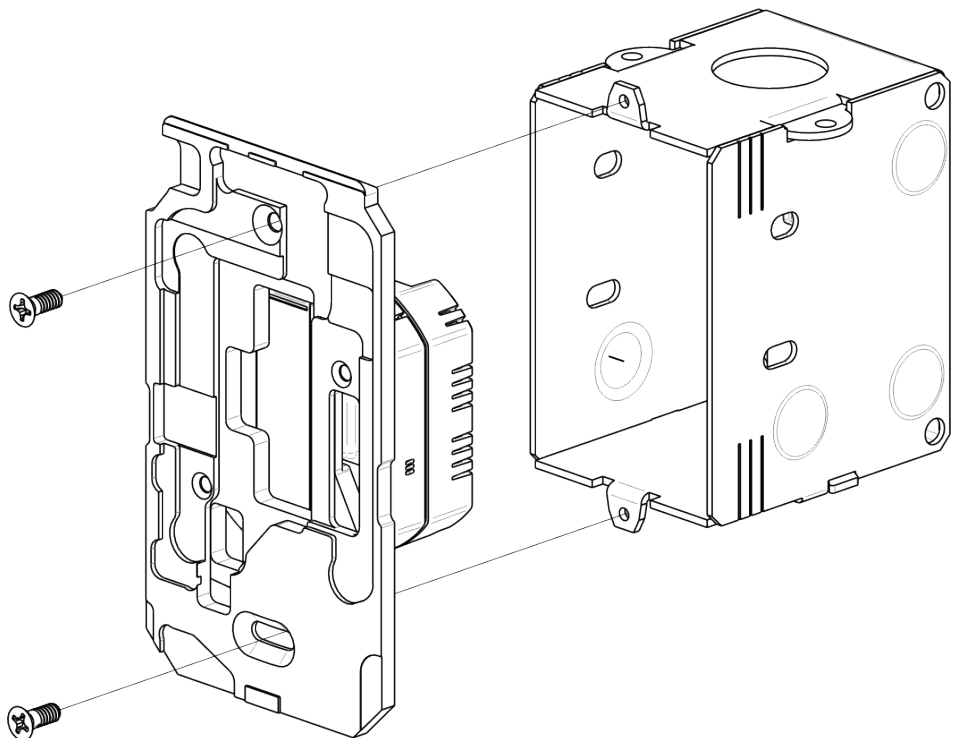

Figure 2: LCM with mounting bracket for US Single Gang Keypad

Load Control Module

ELECTRICAL CONNECTIONS

The LCM comes with 2 styles of power connections, namely either terminal blocks or flying leads. Flying leads are more common in North America with 120V line power, terminal blocks are more common in countries where line power is 240V. The terminal blocks accept a maximum wire size of 2.5 mm² or 14 AWG. The flying leads can be wired to any size power wire.

Connect Line to terminal L (black power lead) and Neutral to N (white power lead). The Line side of the load (light) is connected to D (blue wire in illustration) and Neutral to N (white wire lead) (see Figure 2). The LCM does not require bonding to earth ground.

FOR TERMINAL BLOCK INSTALLATION:

Strip each power wire's insulation back 6.5 mm (+/- 0.5mm) or 1/4 in. (+/- .020") for insertion into the terminal blocks.

Tighten terminal screws securely (0.3 Nm or 2.7 lb in)

FOR FLYING LEAD CONNECTION:

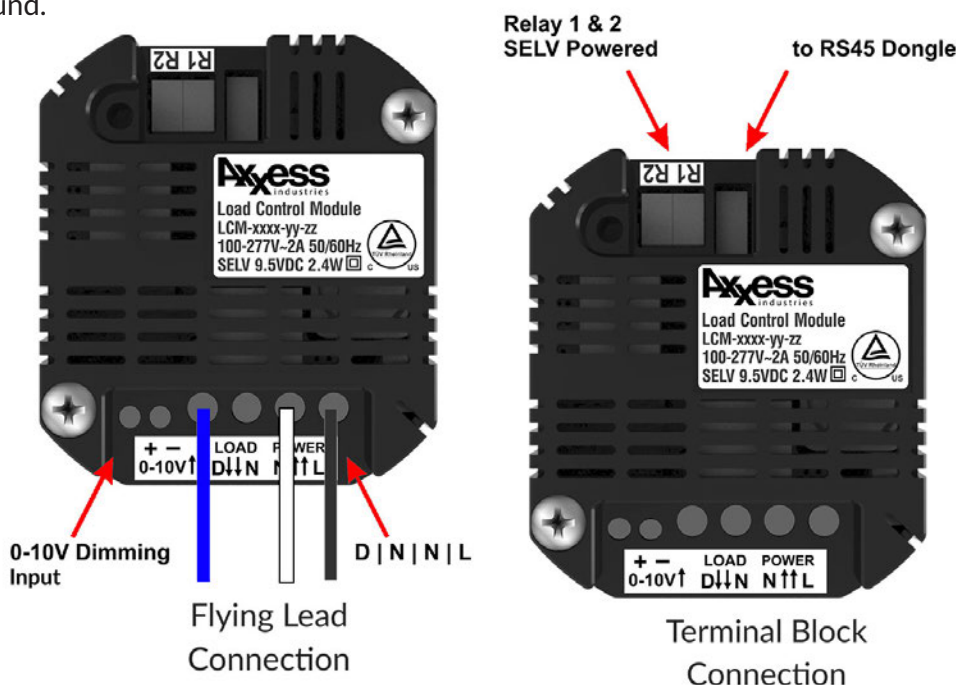

Figure 3: LCM Electrical Connections

NOTE: Colors of in-wall wires can differ depending upon how the fixture was wired by the electrician. Be sure to determine which wires in the electrical box are Line, Neutral, Load, or Bond/Earth/Ground.

If the LCM is to be controlled by an Axxess Keypad, connect the 10 pin ribbon cable from the Keypad to the connector on the LCM. (ribbon cable colors may vary)

If the dimming function is to be controlled by 0-10V input, connect low voltage wire to 0-10V terminals



Load Control Module

FINISHING

Fit the electrical wires back into the wallbox by gently folding the wires into a zigzag pattern and pushing the Load Control Module into place. Attach mounting bracket to wallbox with appropriate countersunk screws.

When the wiring and installation is complete, turn on the mains power at the breaker panel/fuse box. Test the Load Control Module to see if it is working properly. See “Operation Instructions” on how to control and test the LCM.

MOUNTING WITH KEYPAD

To mount with a keypad, follow the instructions above to install the LCM into the electrical box. Plug the ribbon harness from the LCM into the keypad. Hang the top of the keypad on to the top lip of the mounting plate, bring in the bottom of the keypad and secure with the set screw.

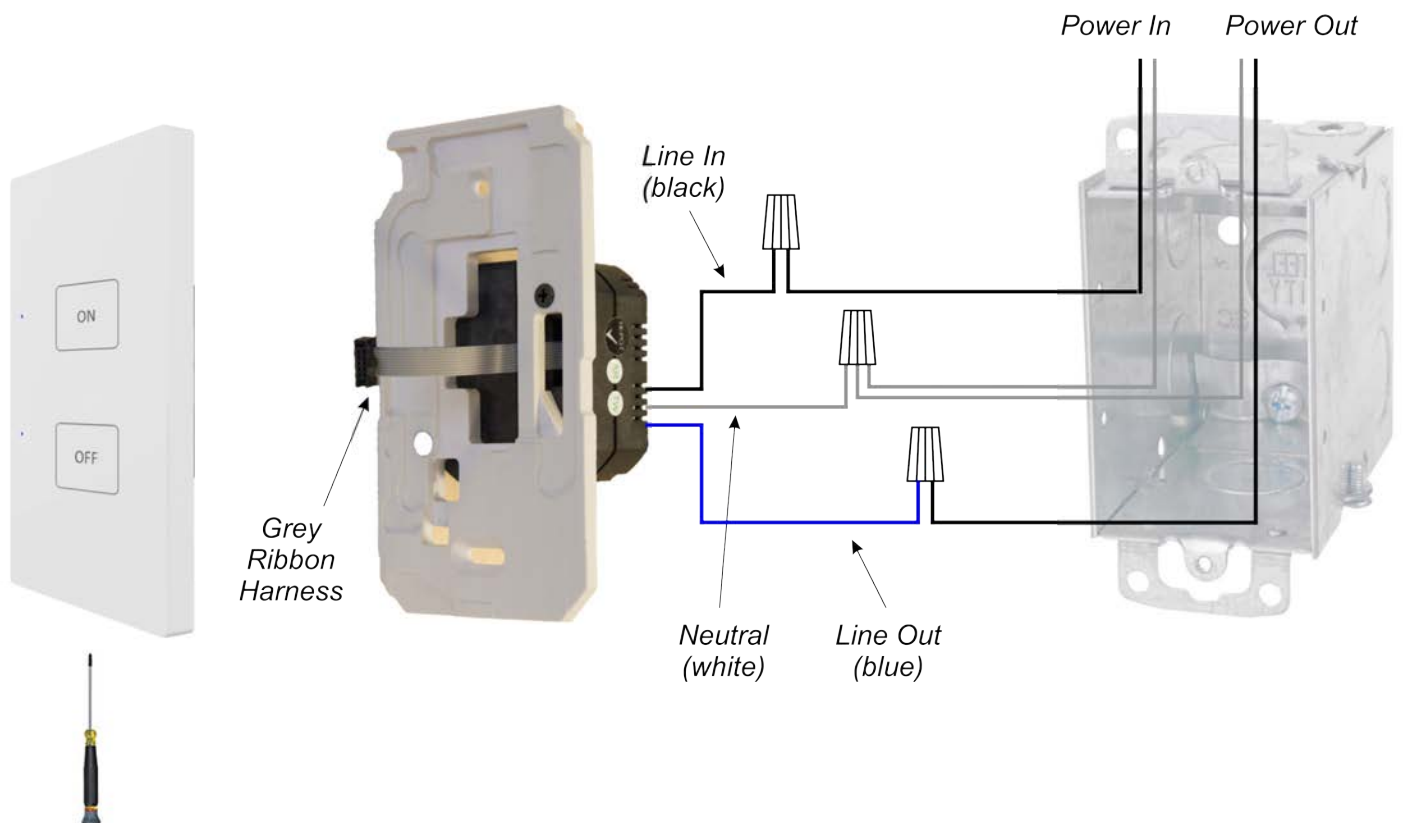

Load Control Module

OPERATION

ZigBee Network operation

The device has to be mounted within the range of the ZigBee network in which it is to operate.

Network range will vary depending on the radio strength of the router it is connected to, as well as physical features causing attenuation of the signal. Typically the device can communicate in excess of 400 feet in the open, however range will be significantly reduced indoors. Ensure the network is designed properly and that router strength and physical barriers are considered.

The Load Control module is operated through tap sequences. Use a paperclip to press the button.

Taps	Description
4	JOIN network
7	ALLOW JOIN (of other devices to the network)
8	SETUP
13	LEAVE network
15	RESET device, watchdog timeout.



NETWORK LED Operation

JOIN operation, LED flashes at 2Hz until JOINED, when it goes solid ON for 4 seconds

LEAVE operation, LED flashes 8 times

ALLOW JOIN, flash for duration of period (120 seconds) Not necessarily supported by all ZigBee networks.

TEST/SETUP Toggle Dimmer output from minimum output to maximum output.

RESET, when device boots LED goes solid for 4 seconds to indicate JOINED, or flashes 8 times to indicate no network



Load Control Module

DRIVERS

Control4 device Drivers are available for download on our website:
axxind.com/dealers/drivers

TROUBLESHOOTING

It is important to make sure that the device is wired properly. Test that the device has power and is properly connected by 8 tapping the network button, which should toggle the lights ON and Off.

If the dimmer can be controlled locally but you cannot dim the output from the automation system, there is a network issue. Make sure the LCM is in range of the ZigBee network and confirm that it is joined. If necessary, leave the device and rejoin it to the network. If the connected lights do not work from local controls, there is a problem with the wiring or with the light fixture.

Double check that the device is wired correctly and try to test again by 8 tapping the network button.

To test that the device is powered up, confirm that there is LED feedback when you tap the network button to join or leave the device. If there is no LED feedback, the device has no power. Check wiring and connections. If they are correct then there may be a problem with the device.

Also check to see that the load is not too large. There is a 2 A max load, however, some light fixtures have large in-rush currents and the LCM safety circuit may be preventing the lights from turning on. Test with a smaller load (for example 15 - 30W). If that works, then the LCM is functioning, but the load you tried to connect is too large.

If it still does not turn the lights on, then there may be a problem with the LCM.

Troubleshooting instructions can be accessed on our website at:
axxind.com/about/automation/